

BENCH INSTRUCTIONS
KBC2350

REV# 1
6/28/22

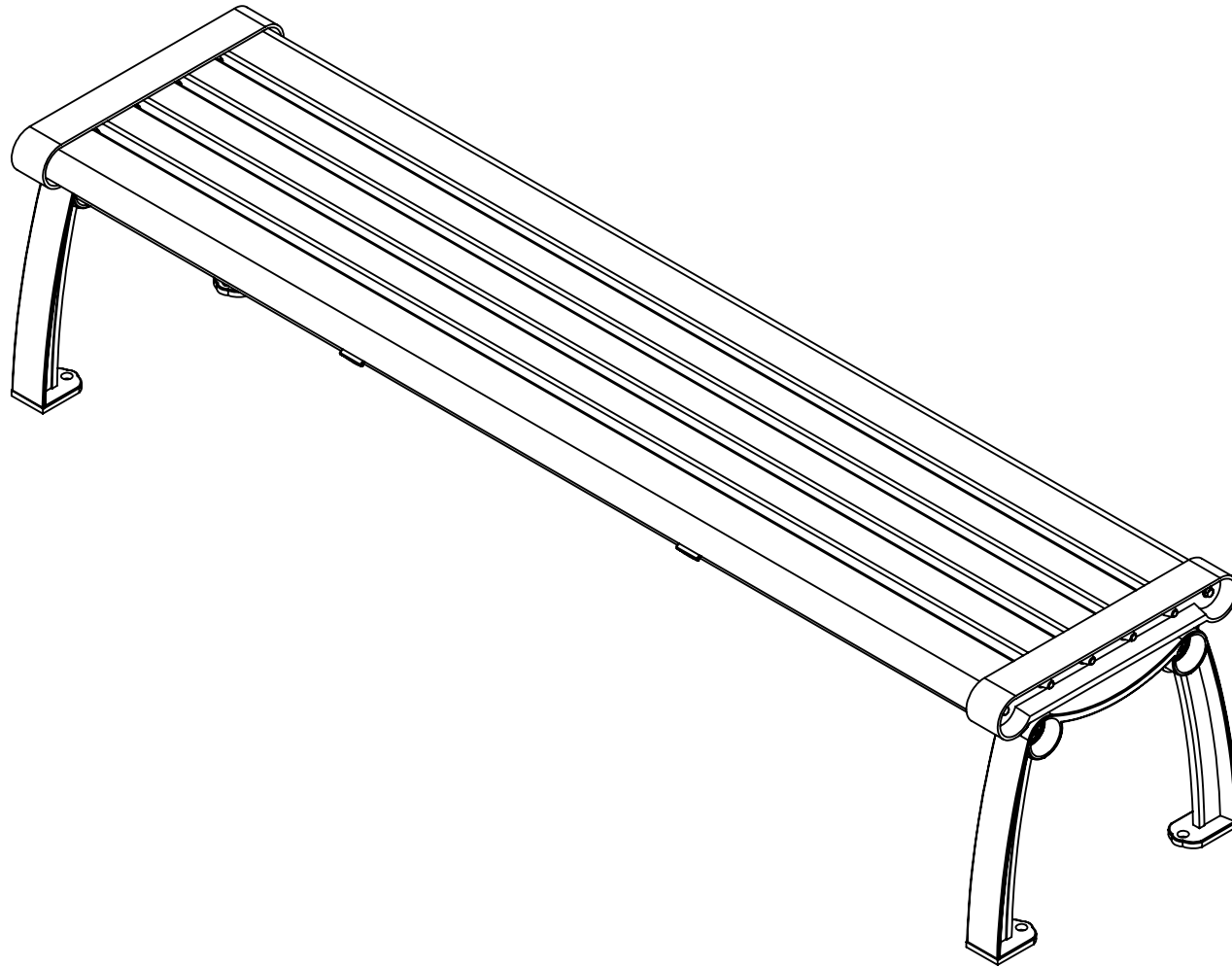

BENCH INSTRUCTIONS KBC2350

NOTE: IT IS IMPORTANT TO KEEP ALL SCREWS LOOSE DURING ASSEMBLY UNTIL ENTIRE BENCH IS ASSEMBLED

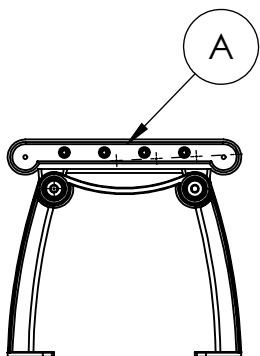

2
Bench Ends
PRT-END-KBC2350-90

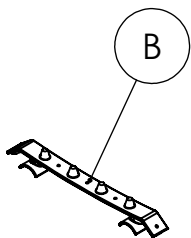

2
Seat Support
PRT-BRKT-KBC2350-90

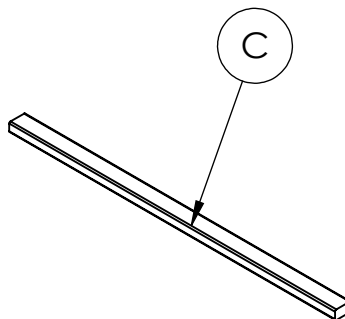

3
Square Seat Slats
ABC-P0083

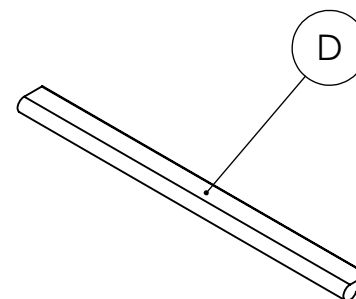

2
Tear Drop Seat Slats
ABC-P0085

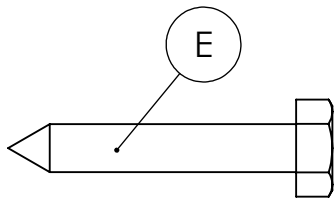

4
1/4x1-1/2 HEX LAG
HLAG025C150188

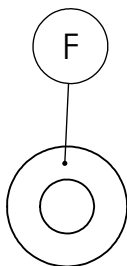

4
1/4 USS FLAT WASHER
WUSS025WAS188

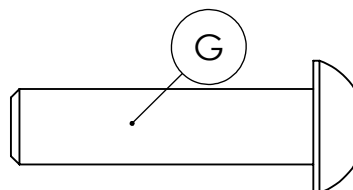

4
M10 X 40 Button Head
SCBH100C040188

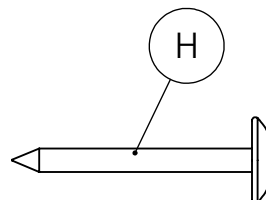

10
#10 x 1-1/4 PHIL PAN TRUSS
SMPT010C125A188

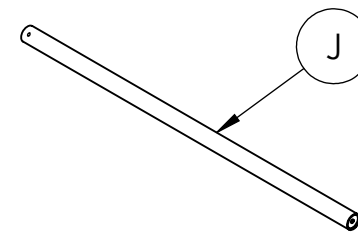

2
Tube Supports
HAS1030-BK 4'

REQUIRED TOOLS (NOT INCLUDED)

- 1 - 7/16" SOCKET WRENCH
- 1 - 6mm ALLEN WRENCH
- 1 - PHILLIPS HEAD BIT
- 1 - 1/8" DRILL BIT
- POWER DRILL

**HARDWARE &
TOOLS REQUIRED
FOR ASSEMBLY**

2/4

BENCH INSTRUCTIONS

KBC2350

STEP 1 Frame Assembly

- Stand one bench end (A) upright
- Place a tube support (J) in the bench end (A)
- Align the hole in the bench end (A) with the hole in the end tube support (J)
- Attach tube supports with 10mm button head cap screws (G) by a few threads, about 2 full turns
- Repeat for the opposite end of tube support (J) and the other bench end (A)

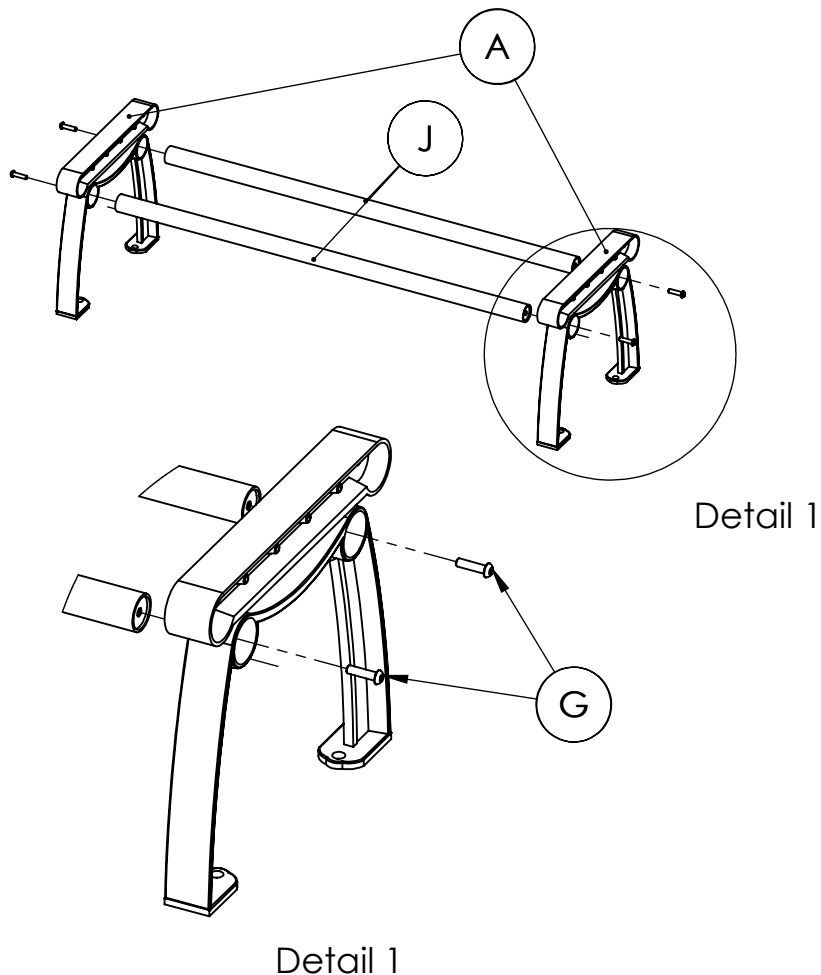

STEP 2 Seat Assembly

- Place the seat supports (B) over the tube supports (J)
- Locate 2 tear drop board (D) and 3 square boards (C).
- Position them in the order shown below into the loose frame pockets in the bench ends (A) and over the seat support (B)
- Slide the bench ends (A) together and tighten the 10mm button head cap screws (G) in the bench ends (A)

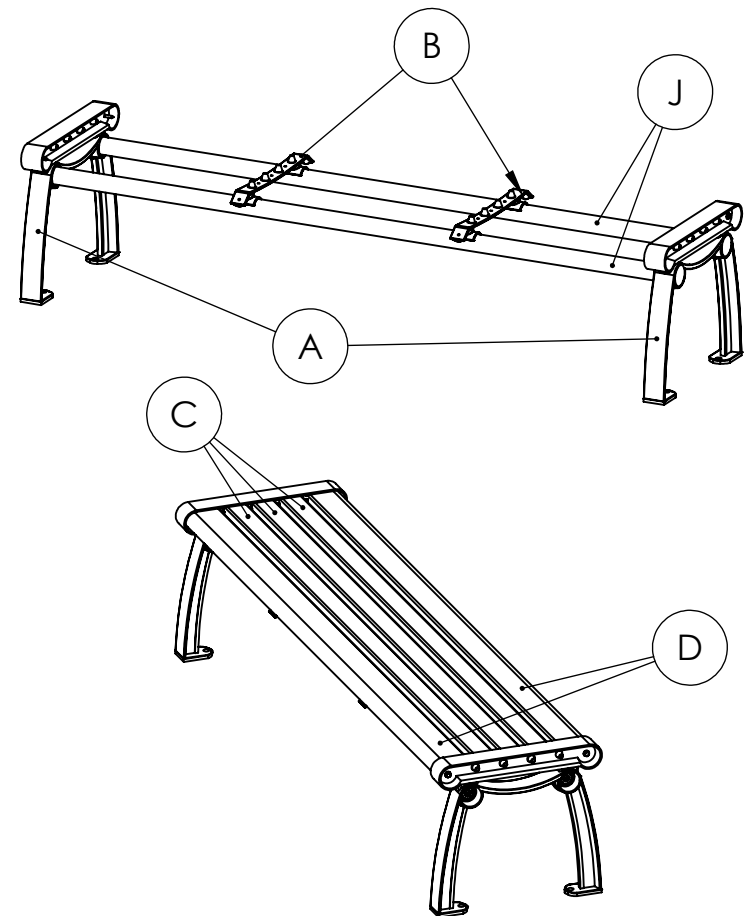

BENCH INSTRUCTIONS

KBC2350

Step 3 Secure Bench End

- Hold the tear drop board (D) against the side of the bench end (A)
- Secure the tear drop board (D) with a 1/4" x 1-1/2" lag screw (E) and 1/4" flat washer (F) at each end as shown below

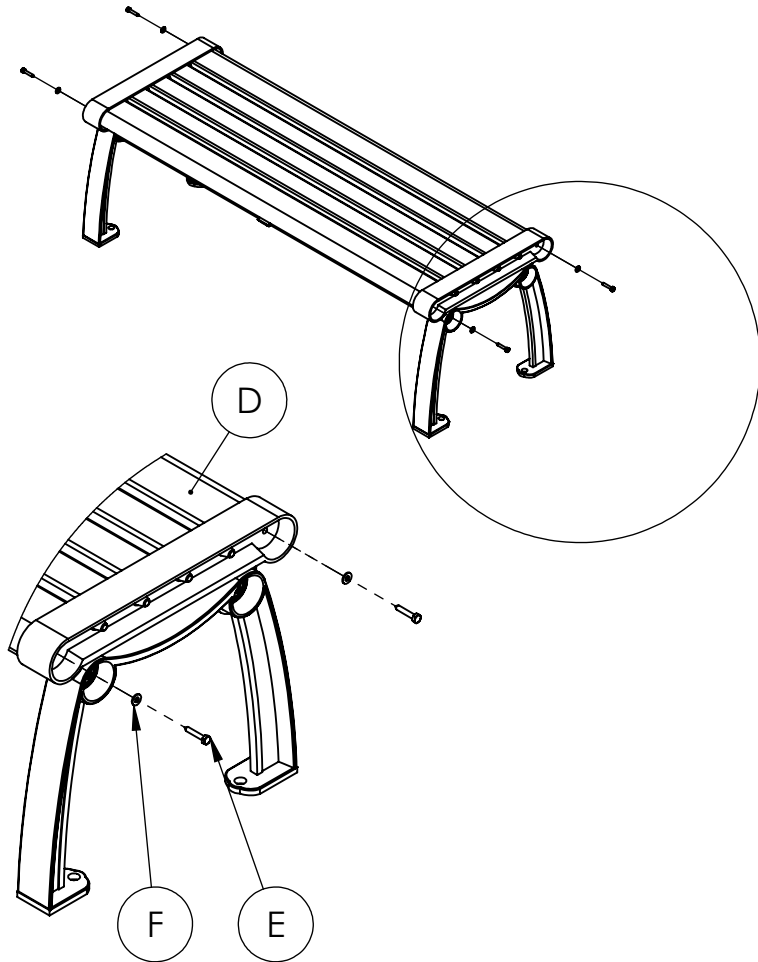

Step 4 Attach Seat Support

- Carefully flip assembly over so top side is down
- Align the seat support (B) with the marked location in the square boards (C)
- Attach the seat support (B) to the square boards (C) with #10 pan head screws (H) at each hole location
- Use a 1/8" drill bit and predrill a 1/2" deep hole into the outside teardrop board (D)
- Secure tear drop boards (D) with #10 pan head screws (H)
- Carefully flip the assembly over and place in the desired location
- If mounting to ground, use the kit BNHRD-4

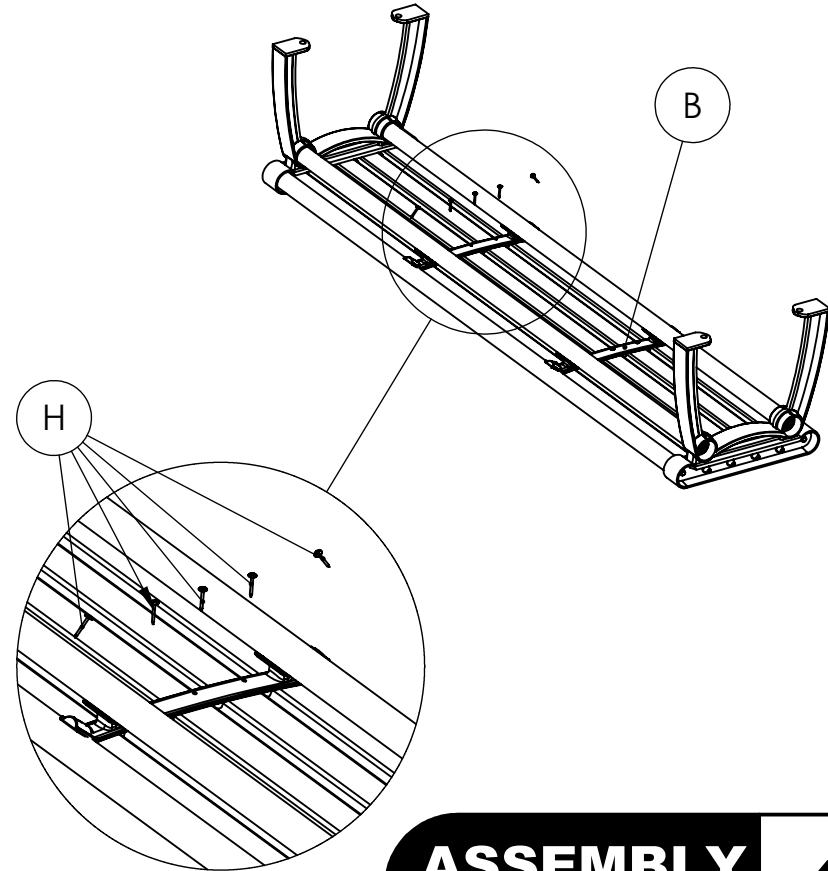

BENCH SPECIFICATIONS KBC2350

REV# 1
6/28/22

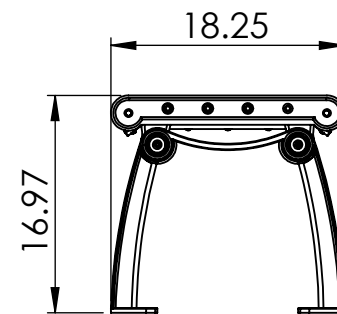
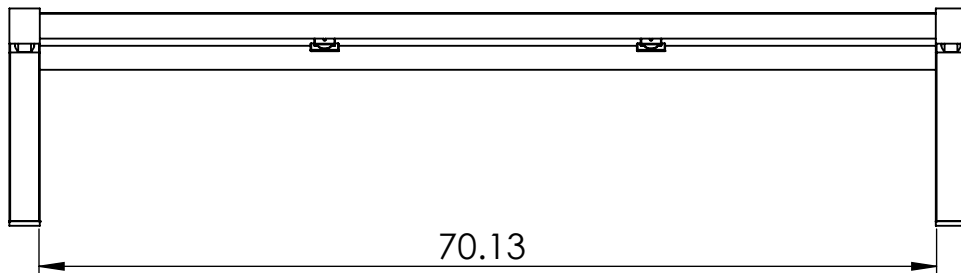
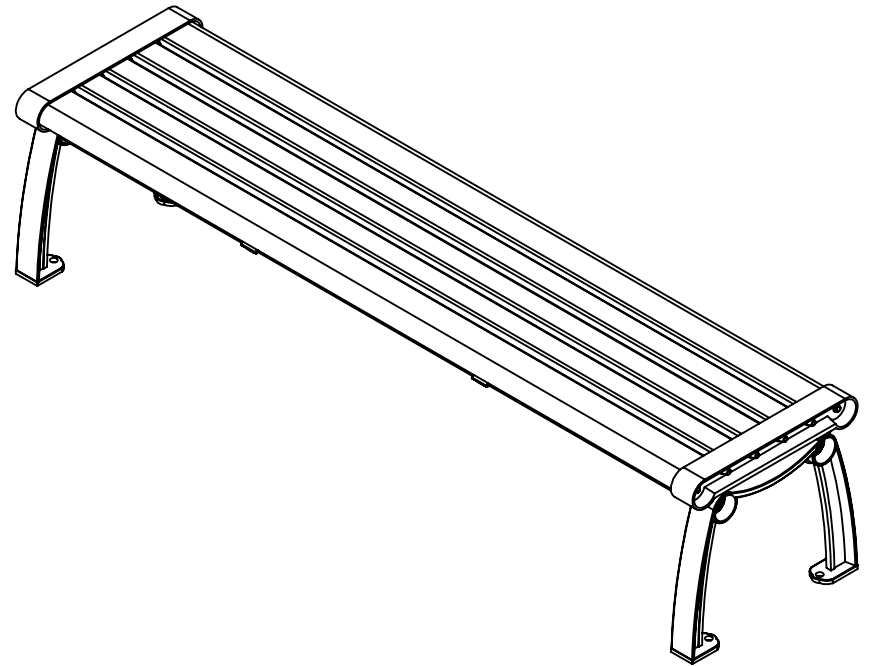
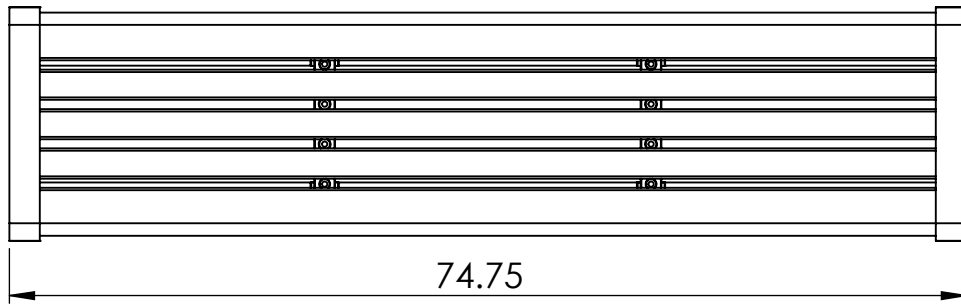

CONSTRUCTION MATERIALS:
Recycled Plastic
Cast Aluminum
HARDWARE:
Stainless Steel

ALL DIMENSIONS ARE SHOWN IN INCHES